



TELEX NO. 932459

AIRCRAFT CORP. - P. O. BOX 147 - ELMIRA, N. Y. 14902 - (607) 739-3821

September 11, 1984

Mr. Clayton Vickland
629 N. Monroe St.
Arlington, VA. 22201

Dear Mr. Vickland:

Enclosed is the E.C.O. covering the installation of bushings to the aileron bellcranks on the 2-22. Schweizer engineering has also approved this repair for all 1-26 model aileron bellcranks, part number 26121-001.

Schweizer Aircraft has NAS77-4-38 bushings in stock at \$10.51 each plus shipping which are adaptable to these applications.

Our source of these bushings was:

Lawrence Engineering & Supply
P. O. Box 35067, 8656 Denton Dr.
Dallas, TX. 75235

I hope this satisfies your needs at present. Feel free to call if you need further assistance.

Sincerely yours,

SCHWEIZER AIRCRAFT CORP.

Steven P. McKeown
Parts & Customer Service

ern
enclosure

SCHWEIZER AIRCRAFT CORP.

Handwritten signature

ENGINEERING CHANGE ORDER								CHG.	LET.
.TLE:		AILERON BELLCRANK INSTALL, WING STA. 181.18							
INC.	BY	EFFECTIVITY	SPARES	PART AFFECTED	No	ECO. SERIAL	22-554		
ECO.	BY	CARD POSTED	YES	TOOLS AFFECTED	No	D.C.R. SERIAL			
DATE	5-10-79	CHECKED	K 5-10-79	STOCK DISPOSITION	---	DWG. NO.	226476 C		

CHANGE: CREATE -9 BUSHING AS SHN. BELOW 2 REQ'D. FOR SPARES USE IN REMOVING SLOP DUE TO WEAR IN BELLCRANK ASS'Y.

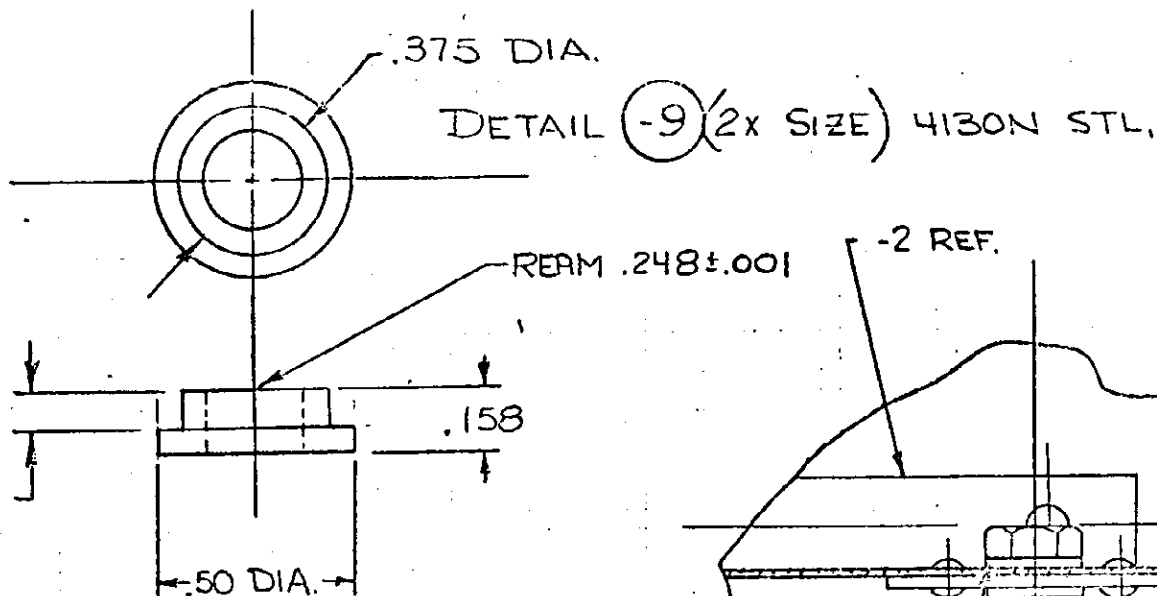

TO INSTALL -9 DRILL EXISTING HOLE IN -2 & -3 TO .38 DIA.

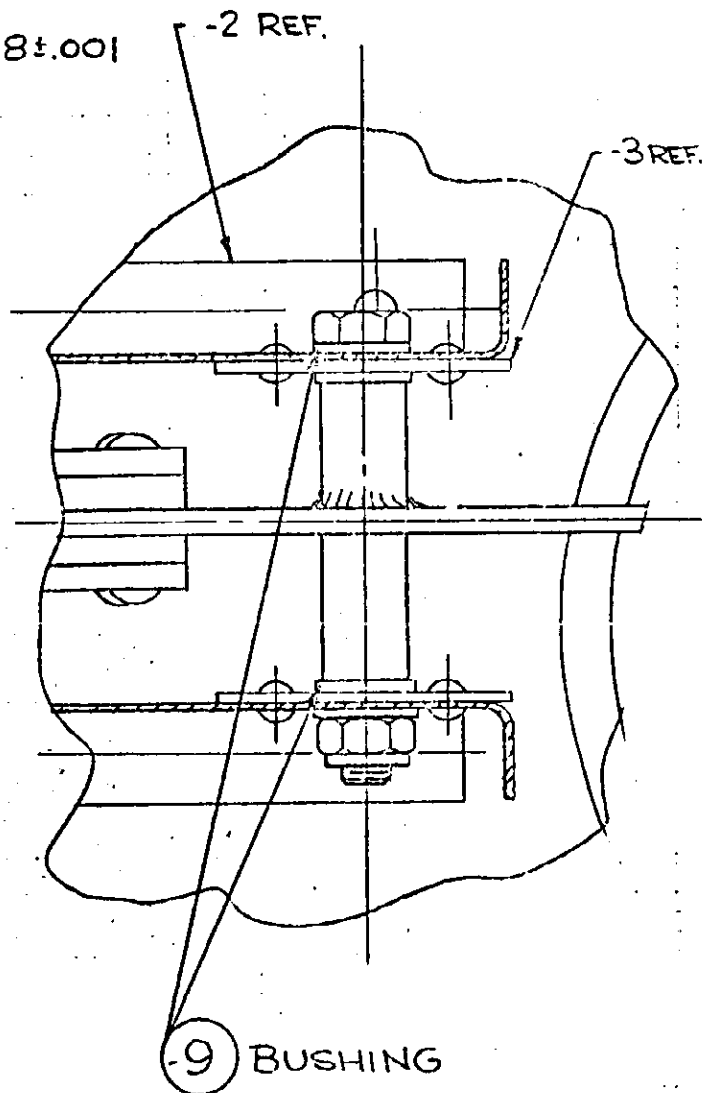

REASON:

NAS 77-4-38
M. 218.10436
P. 10.51